



PHARMA  
— HUB —



**CSV**  
Life Science  
**ENGINEERING &  
GMP SERVICES**

**CSV**  
Active  
**API TRADING**

**PHARMA  
HUB**  
**PROCESS  
EQUIPMENT  
SUPPLY**

**CSV**  
Containment  
**CONTAINMENT  
SOLUTIONS**

**CSV**  
Construction  
**CONSTRUCTION**

**OFFICINE  
GALESSO**  
**EQUIPMENT  
MANUFACTURING**

**CSV**  
Life Science Group



• Locations

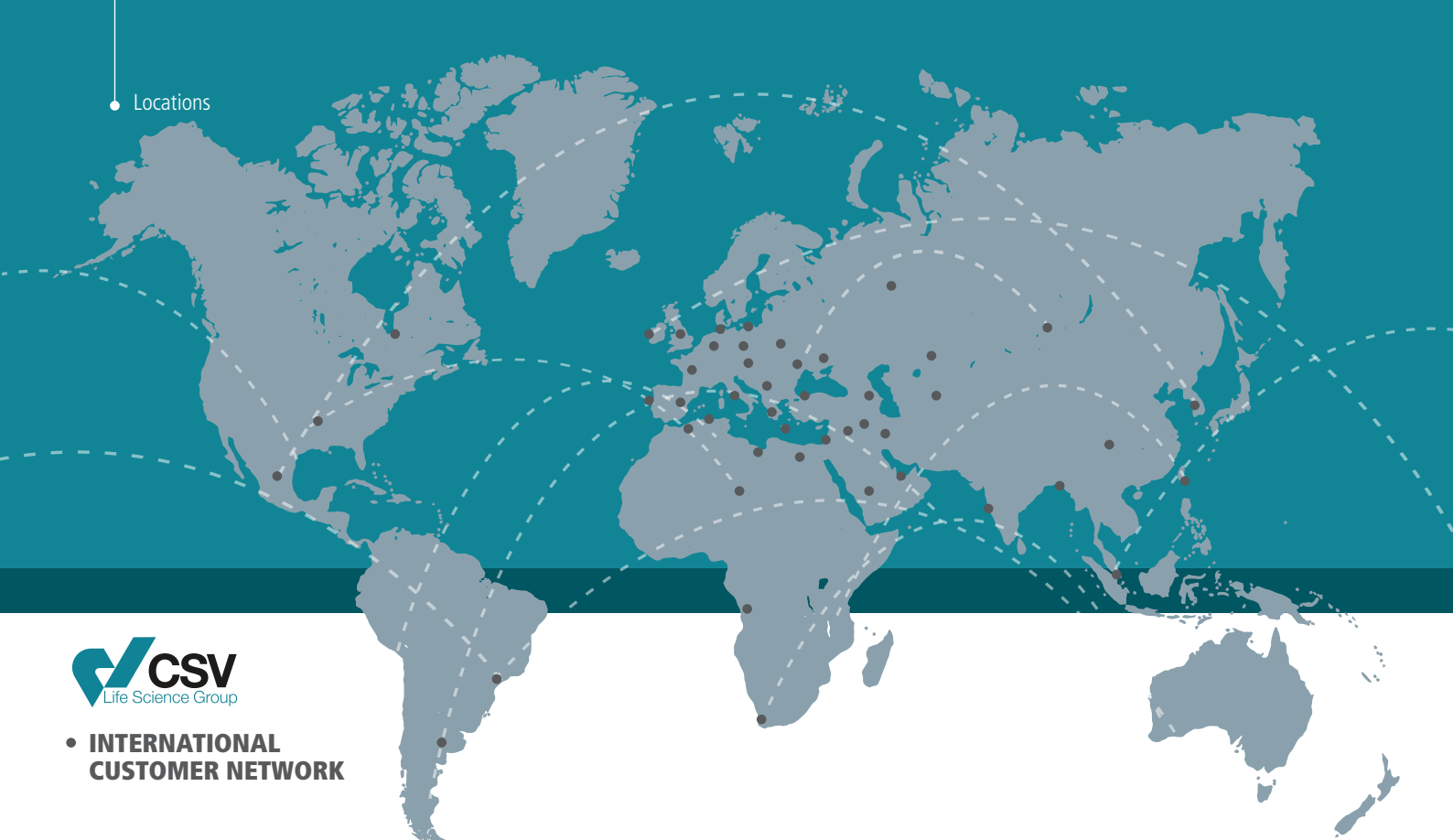

• **INTERNATIONAL  
CUSTOMER NETWORK**

○ **Milan**  
CORPORATE OFFICES  
AND TECHNICAL

○ **Rome**  
MECHANICAL WORKSHOP

○ **Formia**  
TECHNICAL OFFICE

○ **Turin**  
ISOLATORS  
ASSEMBLING  
AND FAT AREA

○ **Capetown**  
BRANCH OFFICE

○ **Athens**  
BRANCH OFFICE



## ABOUT US

Pharma Hub is comprised of professionals mainly operating in the pharmaceutical chemical sector, offering Design, Construction, and Validation services. We are a reliable, capable, and at the same time flexible partner for achieving and completing our clients' projects.

Pharma Hub represents a valid answer for all large and small entities wishing to operate in the current scenario: by designing, constructing, and validating facilities in compliance with the Good Manufacturing Practice (cGMP) codes.

Pharma Hub is made up of professionals who have gained a decade of experience in the field of Engineering and Validations in the pharmaceutical chemical sector.

The expertise acquired, along with our flexibility, represents the best assurance to guarantee the most effective solution to the problems of every business reality in full compliance with GxP regulations.





## PROCESS DESIGN

In the pharmaceutical and chemical world, where the successful operation of the equipment depends on its customization with respect to the process and the unique characteristics that each production intrinsically has.

Pharma Hub supports its customers starting from the early stages of project development to obtain the right process technology ready to be realized and installed. Main design phases proposed are:

- Conceptual Design
- Basic Design
- Detailed Design
- Design for Construction

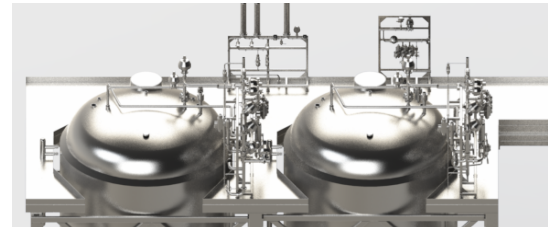
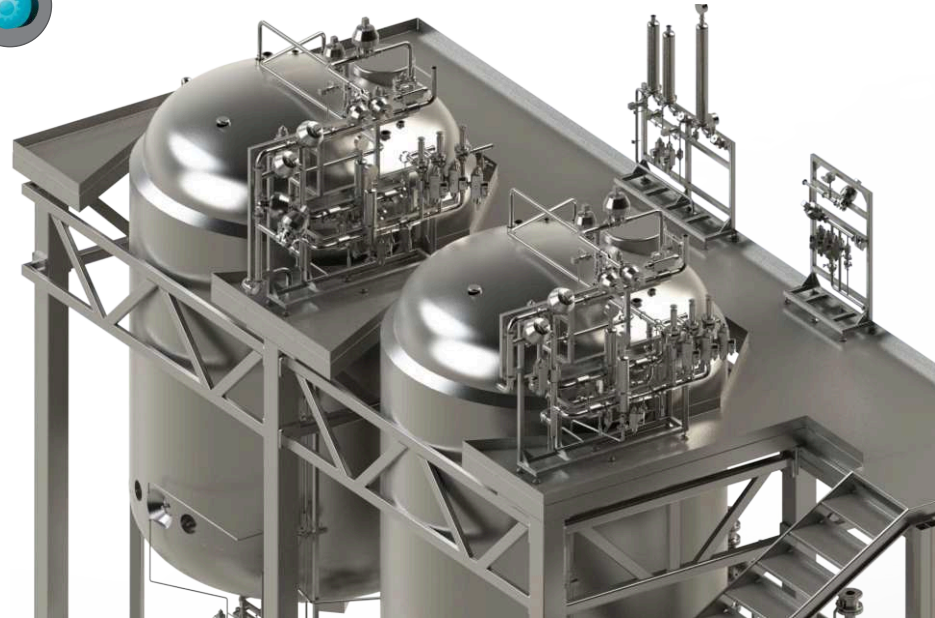





# DESIGN AND MANUFACTURING OF PROCESS SOLUTIONS

Pharma Hub, thanks to its knowledge of Good Manufacturing Practices and its specific know how on different areas (Validation, Engineering, Chemistry, Maintenance, etc.) related to the process, is the ideal partner to design and manufacture specific process equipment with particular attention to each stage of the production process and the utilities available at the customer's site.





## PROCESS EQUIPMENT FOR LIQUIDS

Pharma Hub, as part of CSV Life Science Group, is a reliable supplier for a wide range of tailor made and standard equipment for pharmaceutical products preparation by means of an accurate process construction design.

- Compounding and Solution Preparation Skids
- Fermentation Skids
- Reactors
- Stirring vessels (fixed and mobile)
- Vessels





## PROCESS SOLUTIONS UNIT & EQUIPMENT

In order for a process plant to function correctly, the surrounding equipment also plays an important role. Pharma Hub is therefore also the ideal partner for the supply of ancillary equipment:

- CIP & SIP Systems
- CIP & SIP Units
- Thermoregulation units
- Mixing and Transfer Systems







# OINTMENTS, GEL AND HIGH VISCOSITY PRODUCTS PROCESS SOLUTIONS

Designing and creating equipment for the production of products such as creams and gels requires great attention to the physical parameters of the product in order to correctly size the critical functions of the machine itself. Pharma Hub, which over time has been involved in various projects for the production of high viscosity drugs and medical devices, will be able to find the perfect technical process solution for your production needs.





## LSTK PROCESS SOLUTIONS

Pharma Hub designs and manufactures complete turnkey solutions for the production of pharmaceutical products be these oral or sterile liquids or even highly active APIs. Each system, in addition to complying with all national and international standards and guidelines (euGMP, FDA, etc.), is highly customizable based on each customer's needs.





# AUTOMATION

Each system created must function according to the specific characteristics defined in the design phase. Designing and mechanically building the equipment in an impeccable manner is only the first part, but for everything to work as expected, this must be managed through a control system that reflects what is expected from the process logic. For this purpose, Pharma Hub internally develops its own control systems so that these comply with the most stringent pharmaceutical regulations such as the requirements dictated by CFR21 part 11.

The control systems are also fully customizable and scalable based on the specific needs of each customer.

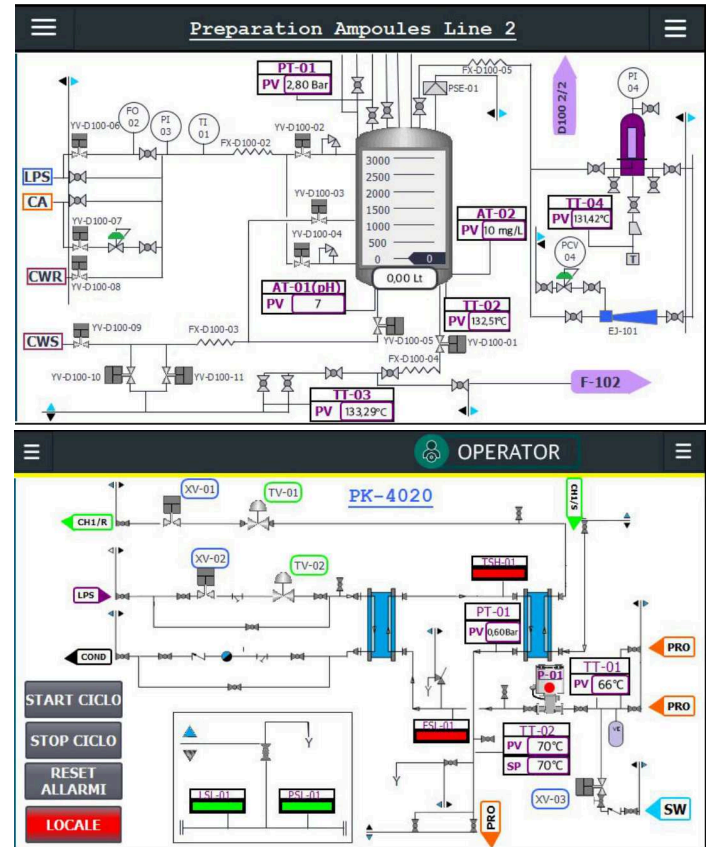







# COMMISSIONING & QUALIFICATION

- GMP review
- Project Management
- VMP/VPP and validation strategy definition
- Risk and impact assesment strategy
- DQ, IQ, OQ and PQ protocols writing and execution
- Validation SOP writing
- Deviation management and remediation plan
- System requalification (HVAC, utilities, sterilization system, ...)
- Periodic review

# METROLOGY

- Calibration plan definition
- Metrology SOP writing
- Instruments calibration
- Calibration data management on customer database

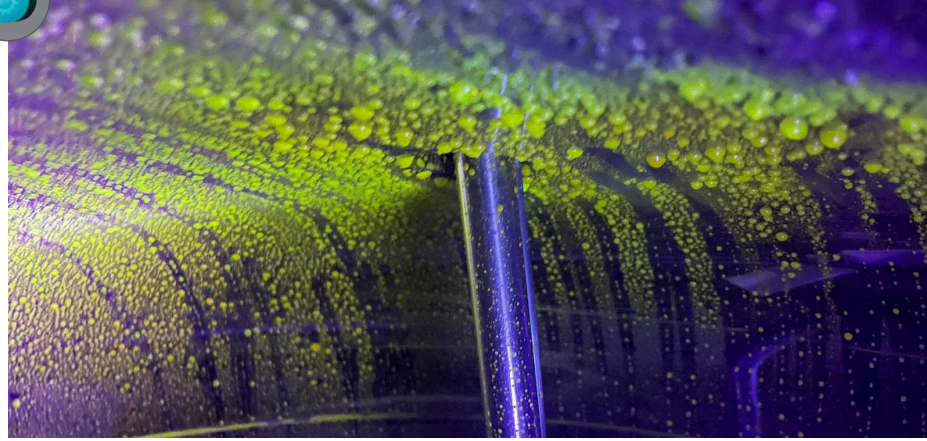





# EQUIPMENT MANUFACTURING

Recently included, Officine Galesso is a mechanical workshop near Rome that has been operating in the pharmaceutical sector for over 50 years and has enabled the Group to produce all equipment for isolation technology and liquid preparation.

This acquisition allows the group to control all stages of its production processes.

- Process Vessels
- Reactors and tanks
- Heat Exchangers
- Carpentry
- LAFs Hoods
- Special tools for pharmaceutical sector

Referring Norms:

- PED Normative
- ASME BPE

Materials:

- 304/316L Stainless Steel
- Hastelloy C-22
- DUPLEX / SALF

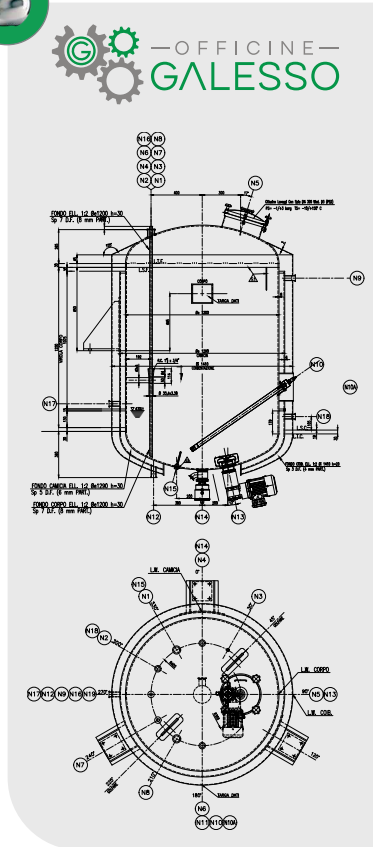

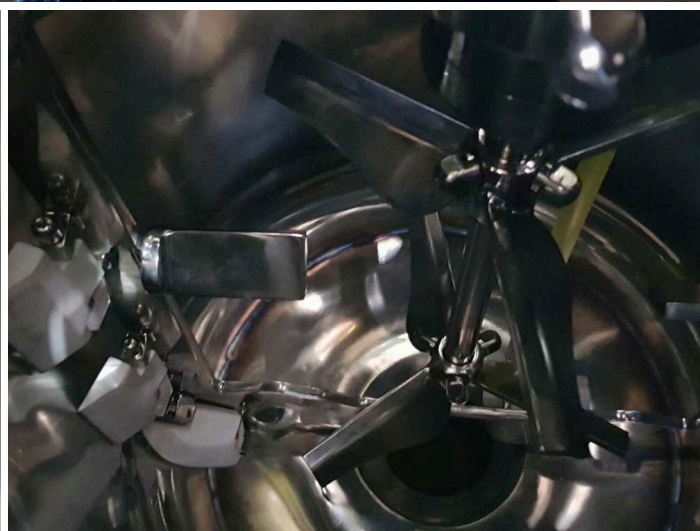
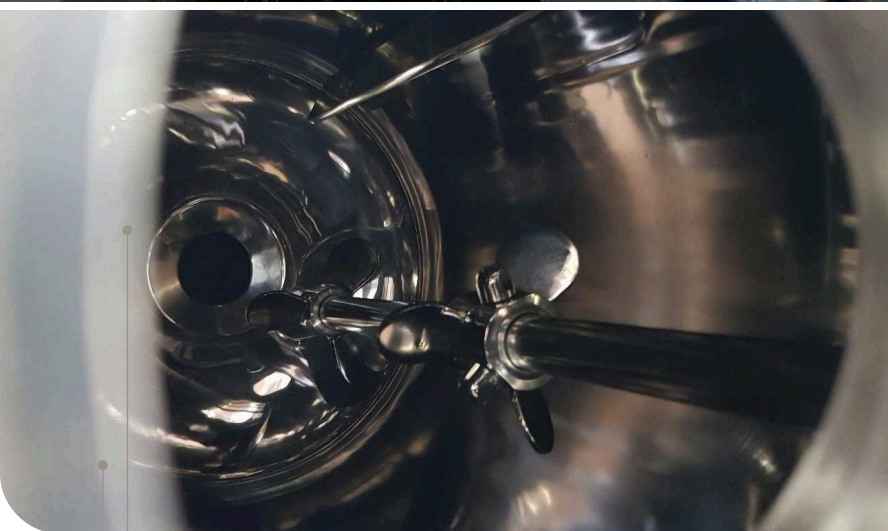



[www.pharma-hub.it](http://www.pharma-hub.it)

**CORPORATE:**

Via Provinciale Ausonia Km 23,00 | 04020 Spigno Saturnia (LT) | ITALY

Phone: +39 0771 64312 | Fax: +39 0771 522504

[info@pharma-hub.it](mailto:info@pharma-hub.it)

