

# DYNAMICA SERIES

CONTINUOUS MOTION CARTONER



# DYNAMICA SERIES MULTIPURPOSE CONTINUOUS MOTION

## DYNAMICA SERIES MULTIPURPOSE CONTINUOUS MOTION CARTONING MACHINES FOR MEDIUM TO HIGH SPEED PRODUCTION

- VERY EASY TO MANAGE AND INTUITIVE TO SET UP
- WIDEST CARTON SIZE RANGE
- COMPLETE ACCESSIBILITY AND QUICK LINE CLEARANCE



# CARTONER



## ERGONOMICS AND MACHINE DESIGN

Compact balcony construction and clean design, ensuring greater accessibility, complete visibility of all parts and enabling installation in a small production space.

The loading position of materials such as cartons, leaflets, booklets, and products has been especially conceived to facilitate the working conditions of the operator.

MODERN AND SUSTAINABLE:  
EXCELLENT PERFORMANCE, LONG  
MACHINE LIFE CYCLE, STRONG  
MECHANICAL STRUCTURE AND LOW  
MAINTENANCE.



DYNAMICA WITH ROLL-ONE LEAFLET  
FOLDING UNIT AND INTEGRATED  
MODULE FOR SERIALIZATION.

# DYNAMICA SERIES MULTIPURPOSE CONTINUOUS MOTION

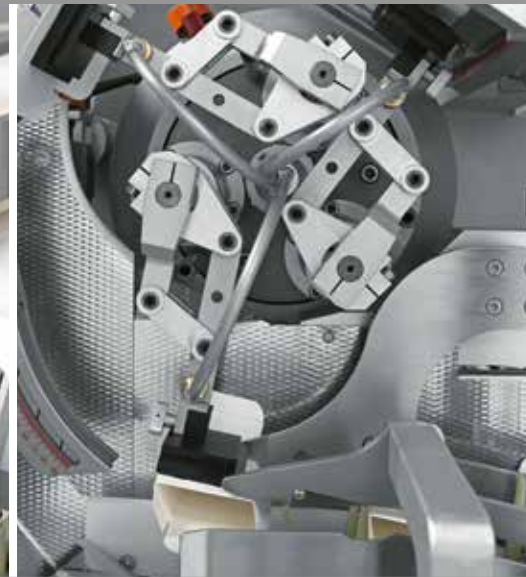

## PRODUCT TRANSPORT CONVEYOR SYSTEM

The product transport system is the most flexible and versatile and has been designed to allow the best integration with product feeders, maintaining excellent stability and orientation right up until the product enters the carton. The length of the system can be varied to accommodate one or more automatic feeders or manual loading stations.

## CARTON MAGAZINE

The height of the magazine guarantees easy carton loading. The carton magazine is the largest in its category (1900 mm). It has been designed to prevent dust from falling on the mechanical parts.

## CARTON PICK-UP OPENING AND TRANSPORT

The withdrawal, opening and positioning of the carton are patented by IMA. This system also allows for the use of cartons made of recycled materials.

- Only a few parts are involved in the changeover
- Carton dust does not fall on any mechanical machine parts.

1. PRODUCT TRANSPORT CONVEYOR SYSTEM
2. IMA ROLL-ONE OR OTHER LEAFLET FEEDING UNIT
3. CARTON PICK UP, OPENING AND TRANSPORT
4. CARTON MAGAZINE
5. PRODUCT INSERTION INTO THE CARTON
6. CLOSING STATION
7. OPERATOR INTERFACE
8. T&T INTEGRATED MODULE FOR SERIALIZATION

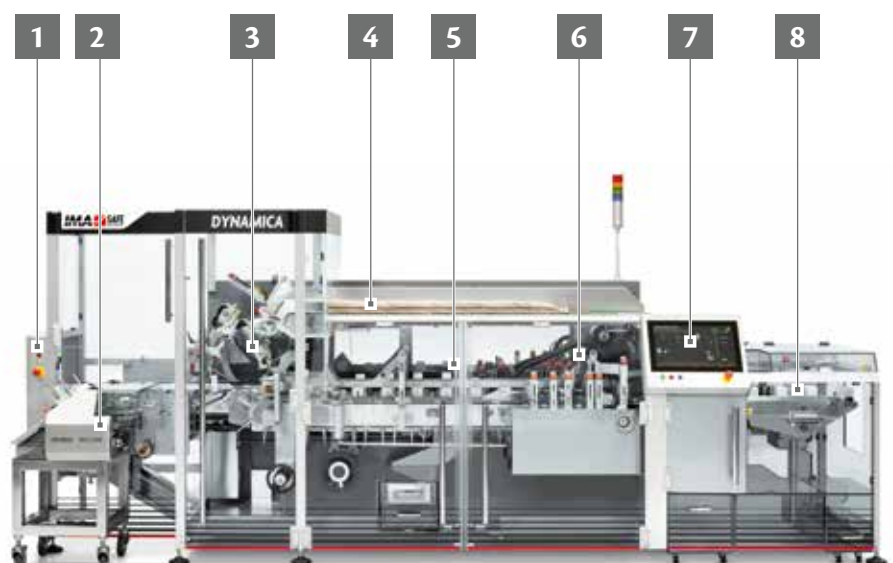

# CARTONER



## PRODUCT INSERTION INTO THE CARTON

Product and accessories (spoon, dispenser, canula, booklets or leaflets) are transferred in to the cartons thanks to a series of continuous movable pushers from the rear side of the machine. Pushers are designed according to the products allowing the most gentle and efficient products introduction.

## CODING AREA

The coding stations are located in an area easily accessible to the operator. Codes can be applied on both sides of the carton by embossing, ink-jet or laser.

## CLOSING AREA

All the common closure types can be implemented. Customized solutions are available on demand. Hot+Cold gluing system, which represent the real tamper evident solution, is available.

## CARTON DRAWINGS

### MAIN CLOSURES

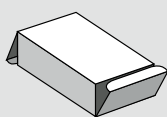

REVERSE TUCK CLOSURE

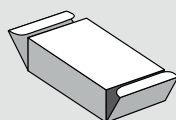

STRAIGHT TUCK CLOSURE



Glue

### GLUE CLOSURES

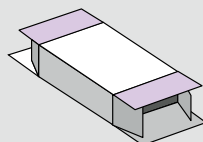

GLUE CLOSURE

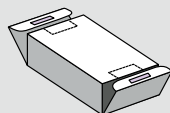

GLUE CLOSURE + TAMPER EVIDENT

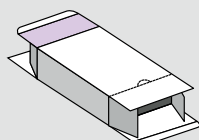

CARTON WITH 4TH FLAP

### SPECIAL CLOSURES

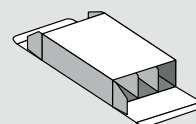

CARTON WITH INNER PARTITION

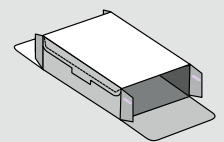

CARTON WITH HINGED LID

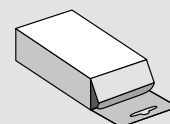

CARTON WITH 5<sup>TH</sup> PANEL

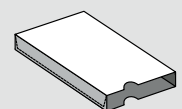

SLEEVE

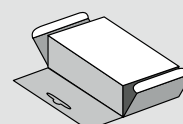

CARTON WITH 5<sup>TH</sup> PANEL

# DYNAMICA SERIES PRODUCT FEEDING SYSTEM

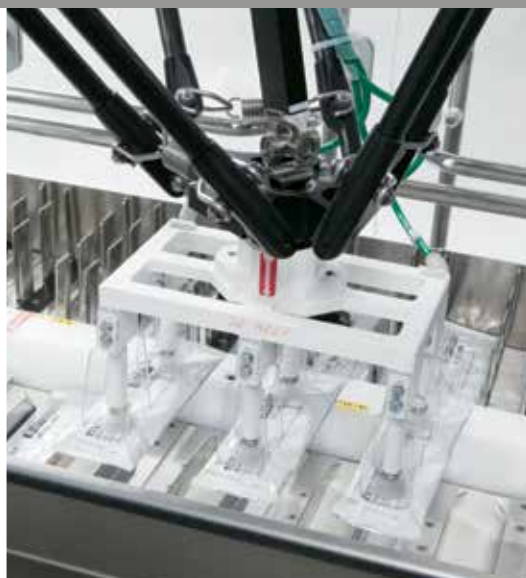

A WIDE RANGE OF PROVEN INFEED SYSTEMS ALLOW FOR A HIGH LEVEL OF AUTOMATION IN THE HANDLING OF PRODUCTS AND ACCESSORIES

## PRODUCTS THAT CAN BE HANDLED ON DYNAMICA:

- BLISTERS
- WALLET STRIPS
- STRIPS
- TRAY PACKS  
ORTHERMOFORMED TRAYS
- ALUMINIUM AND PLASTIC TUBES, SEMI RIGID TUBES, SQUEEZABLE TUBES, ETC.
- AMPOULES, VIALS ANDSYRINGES
- JET-PENS
- FLOW-PACKS
- STICK PACKS
- SACHET PACKS
- INHALERS
- SUPPOSITORIES
- BOTTLES(BOTH PLASTIC AND GLASS)
- COSMETICS(LIPSTICK, MASCARA, NAIL VARNISH, ETC.)
- JARS
- ACCESSORIES(SPOON, CANULA, SPRAY, GLOVES, SERVIETTES, ETC.)



## PARENTAL PAPER PACKS

### Sustainable packaging for pharmaceutical products.

A specific combination of DYNAMICA SERIES, allows to pack fragile products such as vials, syringes and bottles, in a completely recyclable paper display boxes

# LEAFLET AND BOOKLET FEEDING SYSTEMS



## LEAFLET FEEDING SYSTEMS

All kind of leaflets feeding systems can be installed on DYNAMICA for flat, pre-folded and leaflets from reel.

Leaflet transport, from the folding unit up to the introduction, is completely visible and accessible. Leaflets are pre-inserted into the carton through a double mobile blade for higher efficiency.

## IMA ROLL-ONE, LEAFLET FOLDING UNIT

The IMA patented leaflet folding unit is designed to fold flat sheets using an innovative folding system that eliminates the problems of adjustment related to the leaflet thickness.

With only one change part which takes seconds to change, ROLL-ONE almost completely eliminates the time required to complete traditional leaflet change-over requirements. ROLL-ONE is a practical, logical, reproducible and quite system (photo 1-2).

LEAFLET DIMENSIONS	MIN.	MAX.
Wide (mm)	90	210
Long (mm)	80	320



Perfect integration with the unique IMA booklet feeder that does not need size parts. Automatic booklet loader is also available. IMA BOOKLET FEEDER and ROLL-ONE, leaflet folder, are interchangeable.



# DYNAMICA SERIES TRACK & TRACE + SECURITY

## TRACK & TRACE AND SERIALIZATION

ONE LINE - ONE SOLUTION - ONE SUPPLIER

Together with IMA LIFE and IMA BFB, IMA SAFE works actively to find the most functional and GMP solutions starting from the primary packaging (blister, bottles or tubes etc..) to the secondary packaging (cartons, bundles, cases and pallets...). IMA Group is your best partner for supplying complete serialized track and trace lines.



## IMA INTEGRATED MODULE FOR SERIALIZATION

Integrated module to apply camera, laser or ink-jet systems. It is the ideal solution to have a shorter line and higher efficiency because of less units in the line and a constant control of the carton in the tooth belt transport.

Side printing and camera inspection



Top printing and camera inspection







## HMI

The operator interface has been designed to fully meet 21CFR Part 11 and operator requirements. A computer touch screen, with 16:9 colour monitor and graphical user interface, enables easy and intuitive management of the machine's production and status.

The computerized system manages the bar code reader, OCV, and OCR which are completely integrated into the single HMI.

Production data and statistics, troubleshooting, including changeover instructions, maintenance and manuals can be obtained through the HMI screen. Troubleshooting and maintenance can be done also via modem connection. Reconciliation of production data, to facilitate production batch closing, is possible from the machine interface and via Ethernet connection.

## SIZE CHANGEOVER

Extremely easy, intuitive and quick size changeover with adjustments through indicators.



## OPTIONAL UNITS

- Leaflet folding unit
- Booklet feeders and automatic booklet loading systems
- Carton coding (embossing, ink-jet, laser)
- Carton/leaflet/booklet barcode reader/2D code readers
- Glueing systems
- All tamper-evident solutions are available: Hot melt and hot+cold glueing systems
- 5th panel
- Track & Trace solutions
- Labelling application
- CF600 automatic carton feeder
- Possible separation between product feeder and cartoner
- System to feed multiple products simultaneously in the same carton
- Computerized spare parts management
- Printer connected to the HMI
- Computerized line machine statistical data collection or quality control system
- PC production data transfer
- Modem connection

# SALES AND SERVICES

A GLOBAL APPROACH TO CUSTOMER REQUESTS. PROMPT AND EFFECTIVE TECHNICAL ASSISTANCE THROUGHOUT THE ENTIRE LIFE-CYCLE OF THE MACHINE.

GLOBAL MANAGEMENT OF LINE MATTERS FOR COMPLETE LINES SUPPLIED BY IMA.

DIRECT INVOLVEMENT OF ENGINEERING DEPARTMENTS AS REQUIRED.

## SERVICE

IMA machines incorporate the latest developments in technology and are designed to ensure the highest production efficiency with low maintenance.

To obtain top performance from our machines, IMA recommends **technical training courses** for personnel from Production (Operators, Technicians and Supervisors), R&D, Process Transfer Department and the Maintenance Department.

Training courses can be organized at IMA's site or at the customer's plant and are taught by qualified IMA technicians. These Courses are tailor-made and modular and are designed to fulfil each individual customer's specific needs. Basic, Intermediate and Advanced training modules can be applied and special attention is given to the customized units which are fitted on the client's specific machine.

These courses allow the customer's staff to operate the machine, maintain it in perfect working condition and explain how to carry out troubleshooting procedures in the easiest and fastest possible way.

IMA can also provide **course on improving O.E.E.** and increasing production levels which are very important objectives in the pharmaceutical industry.

To guarantee fast and efficient assistance and support, **RSA – Remote Service Assistance**, enables IMA to provide support via modem

and via tele-video conference. RSA enables an immediate analysis of the machine's status and working condition and can be of particular use in case if problems occur.

## SPARE PARTS

The service of supplying original **IMA spare parts** fits completely with IMA's first-class maintenance service concept of taking care of the equipment as well as the customer's investment completely. The Spares Department has a very efficient delivery network, thanks to our Subsidiaries and Agencies, we are able to carry out deliveries of Spare Parts in the shortest time possible.

Extended to most of the IMA machine models, **My IMA Spare Parts** is your virtual shop window available 7 days a week, 24 hours a day intended to provide immediate replies to enquiries, price, delivery time, quotations and order status. All that you need in just a few clicks!

IMA SAFE provides prompt and effective **technical assistance** which covers the entire life cycle of its equipment. This assistance is provided by a dedicated team of experts able to meet our client's needs on a day to day basis. A customer oriented after sales service staff is what distinguishes IMA from the other manufacturers.



# TECHNICAL DATA

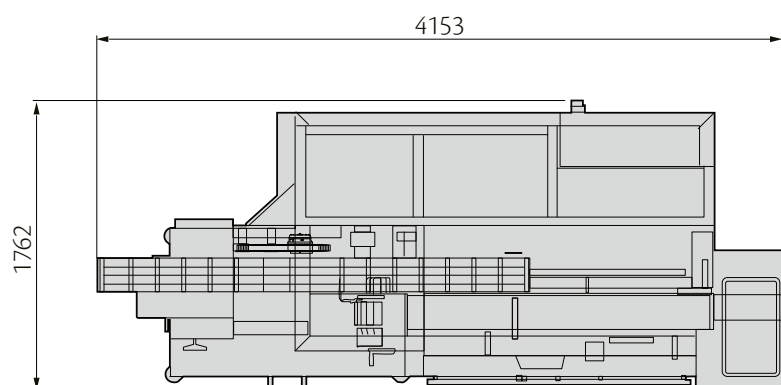
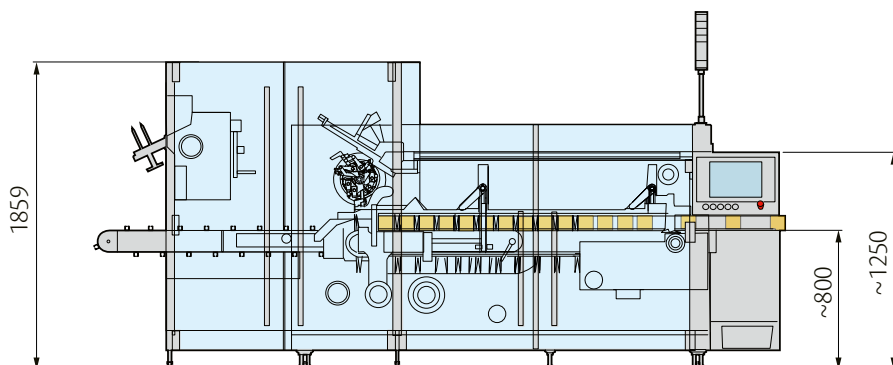

THE DYNAMICA SERIES OFFERS THE WIDEST RANGE IN TERMS OF CARTON SIZE, WIDTH, LENGTH AND HEIGHT - NOT TO MENTION PACK VARIETY.



**Compressed Air Consumption**  
134 NI/min



**Maximum Air Pressure**  
6 atm



**Installed Power**  
5 kW



**Power Supply**  
400 V

CONTINUOUS MOTION CARTONER	WIDTH (A)	HEIGHT (B)	LENGTH (H)	A+B MAX.	PRODUCTION SPEED
DYNAMICA L	25 - 130 mm	12 - 90 mm	65 - 200 mm	180 mm	250 crt/min
DYNAMICA E	30 - 90 mm	15 - 65 mm	100 - 250 mm	155 mm	300 crt/min
DYNAMICA S	25 - 95 mm	12 - 90 mm	65 - 200 mm	180 mm	350 crt/min
DYNAMICA V	25 - 95 mm	12 - 90 mm	65 - 150 mm	180 mm	400 crt/min

The dimensions are indicative and can vary depending on the optional groups chosen and machine lay-out

[www.ima-pharma.com](http://www.ima-pharma.com)



IMA S.p.A.

**IMA SAFE division**

Via I Maggio 14/16 - 40064 Ozzano dell'Emilia (Bologna) - Italy

Tel. +39 051 6514111 - Fax +39 051 6514743

[mktg.packaging@ima.it](mailto:mktg.packaging@ima.it) - [www.ima.it](http://www.ima.it)

